

# **FPS 4400**

## **TRI-SEAL™** **Floating Stage System**



**Franklin Electric**

# 4" Submersible Pumps



The standard FPS 4400 4" submersible pump features the new TRI-SEAL floating stage system. This new stage system further improves efficiency and protects against wear when pumping abrasives (sand). All FPS 4400 pumps are unconditionally guaranteed against sand locking in abrasive well conditions for one full year. For details on how to become a registered dealer and receive a 5-year warranty, contact your local distributor.

## Features:

- 300 series stainless steel hub floats with the impeller maintaining a positive seal
- Phenolic washer provides downthrust protection
- Celcon<sup>®</sup> impeller provides high efficiency performance and abrasion resistance
- Noryl<sup>®</sup> diffuser and disc - proven abrasion resistant material
- Floating stage design allows impeller to float independently
- Removable, spring-loaded check valve
- Maximum water temperature: 120 °F
- Ceramic shaft sleeve and rubber discharge bearing protect shaft and eliminate sand wear
- Powered by Franklin Electric corrosion resistant 4" submersible motors

\* Celcon<sup>®</sup> is a Registered Trademark of the Celanese Corporation.

\*\* Noryl<sup>®</sup> is a Registered Trademark of G.E.

Patented impeller hub seal system seals radially and axially to prevent fluid recirculation, providing high performance in the harshest conditions.

## TRI-SEAL<sup>™</sup> Floating Stage System

U.S. Patent No. 7,290,984

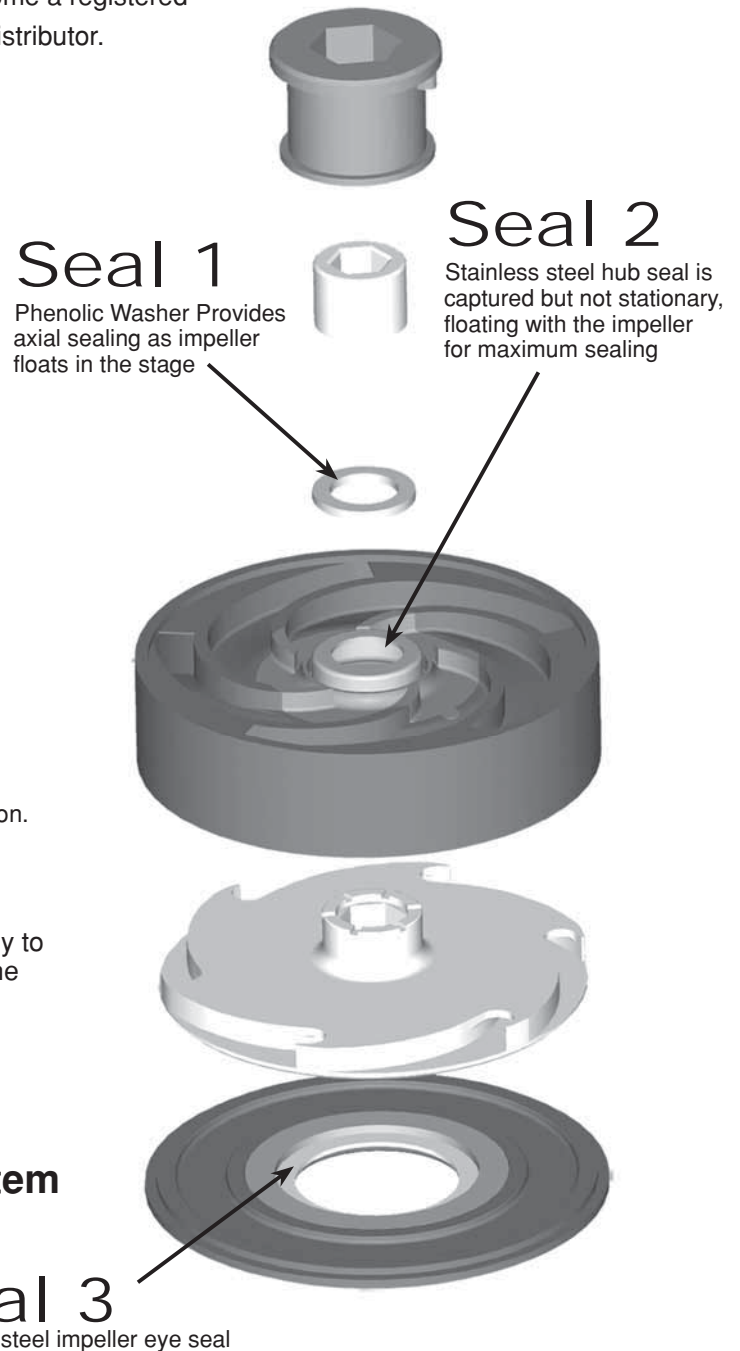

CSA CERTIFIED  
PUMP END ONLY



Drinking Water  
NSF/ANSI 61